

Reg No.: _____

Name: _____

APJ ABDUL KALAM TECHNOLOGICAL UNIVERSITY
SEVENTH SEMESTER B.TECH DEGREE EXAMINATION(S), MAY 2019

Course Code: CE409
Course Name: QUANTITY SURVEYING AND VALUATION

Max. Marks: 100

Duration: 3 Hours

PART A

Answer any two full questions, each carries 10 marks.

Marks

- 1 a) List different type of estimates (4)
- b) Work out the quantity of given materials required for 1:1.5:3 concrete and analyse the unit rate using the details given below: (6)

Description	Quantity	unit	Rate Rs.	unit
20mm (nominal size) broken stone	?	m ³	1300.00	m ³
Sand	?	m ³	1200.00	m ³
Cement	?	Tonne	5700	Tonne
Mason	0.200	Nos	500.00	Each
Man	1.000	Nos	450.00	Each
Women	3.500	Nos	450.00	Each
Man for lifting materials	0.200	Nos	450.00	Each

- 2 a) List the essential documents to be accompanied with the detailed estimate (6)
- b) What is mean by overhead charges? Give the percentage adopted for the contractor's profit and overhead in CPWD DSR 2016 rate analysis. (4)
- 3 Write the detailed specification for brickwork in cement mortar 1:5. (10)

PART B

Answer any two full questions, each carries 25 marks.

- 4 Prepare detailed estimate for the following items of work for the construction of residential building (25)
- (a) RRM for foundation (75cm x 75cm) and basement 50cm x 50cm , Wall thickness 20cm
- (b) Quantity of earth filling inside the plinth
- (c) RCC works for slab (12cm thick), lintel (15cm thick), and sun shade (60cm projection).
- (d) Painting for walls, doors(D1-100x210; D2 80x210) and windows (W2-100x150; W3-150x150;KW1-50x100;KW2-100x100); V(90x60).

All dimensions are in centimetres. Any missing data may be suitably assumed.

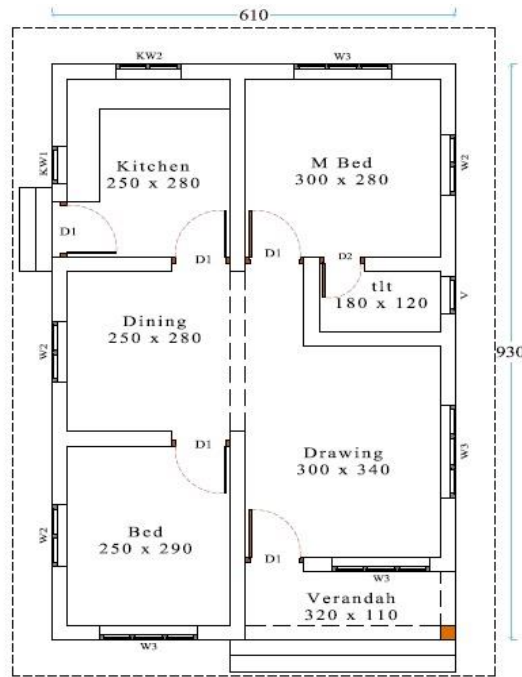

- 5 Prepare a bar bending schedule and quantities of RCC and reinforcement of a simply supported beam of length 6.5 m , depth 50 cm, and width 30 cm reinforced with 3 Nos of 20 mm dia at bottom as straight bar, 2 Nos of 20 mm dia cranked at 45° , 2 Nos 16 Φ at top of beam and 8 mm Φ 2 legged stirrups @ 15 cm c/c (25)
- 6 Prepare a detailed estimate of a Septic tank from the given drawings. (25)

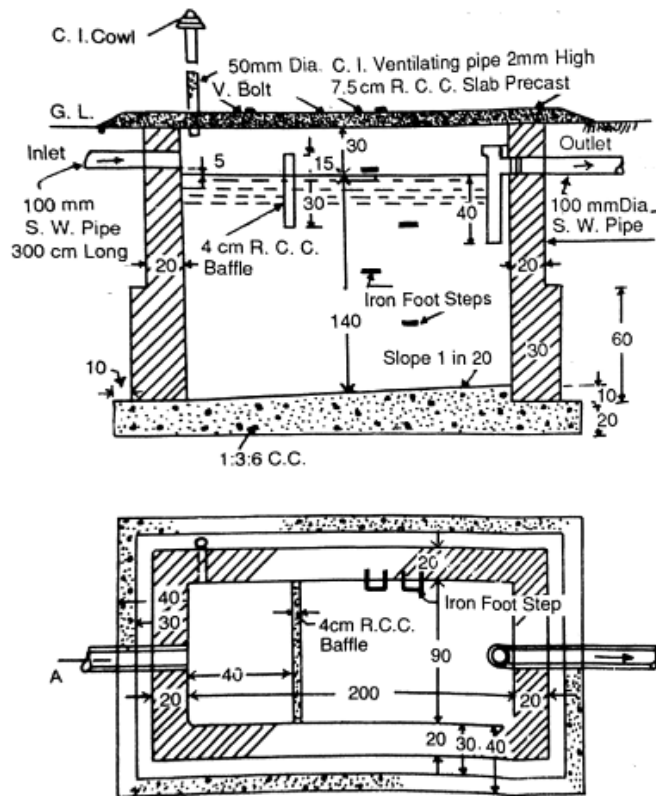

PART C

Answer any two full questions, each carries 15 marks.

- 7 a) Explain valuation and its purpose? (5)
b) What are the methods for calculating depreciation? (10)
- 8 a) Discuss about different methods for finding valuation of a building (8)
b) The cost of construction of a new building according to present market rate is Rs. 80,000/- having a life of 70 years. But if the building is 15 years old determine the depreciation amount which should be deducted from the cost of the new building at 6% compound interest. (7)
- 9 a) A building is constructed at a cost of Rs.2,50,000 on a land purchased at Rs. 50,000. The owner of the property expects a return of 9% on the cost of construction and 8% on the cost of land. The building is estimated to have a future life of 60years at the end of which it requires Rs.3,25,000 for constructing a new building in its place. Determine the standard rent of the property given:
i. Rate of interest for sinking fund at 6%
ii. Annual repairs at 1.5% of cost of the construction
iii. All other outgoings 28% of the net income of the property
Scrap value at the end of the useful life of the building as 10%. (9)
- b) Define salvage value, Scrap value, capitalised value and obsolescence (6)
